

# Cosse Y307L - Y307A

Cosses MFOM - Cosses MFOM pour CI - 2,8 x 0,5

 Acheter ce produit en ligne

[www.mfom.fr](http://www.mfom.fr)

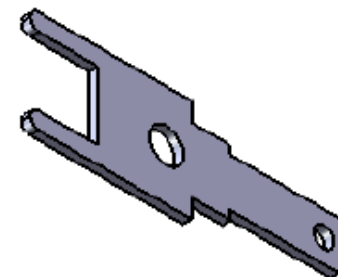
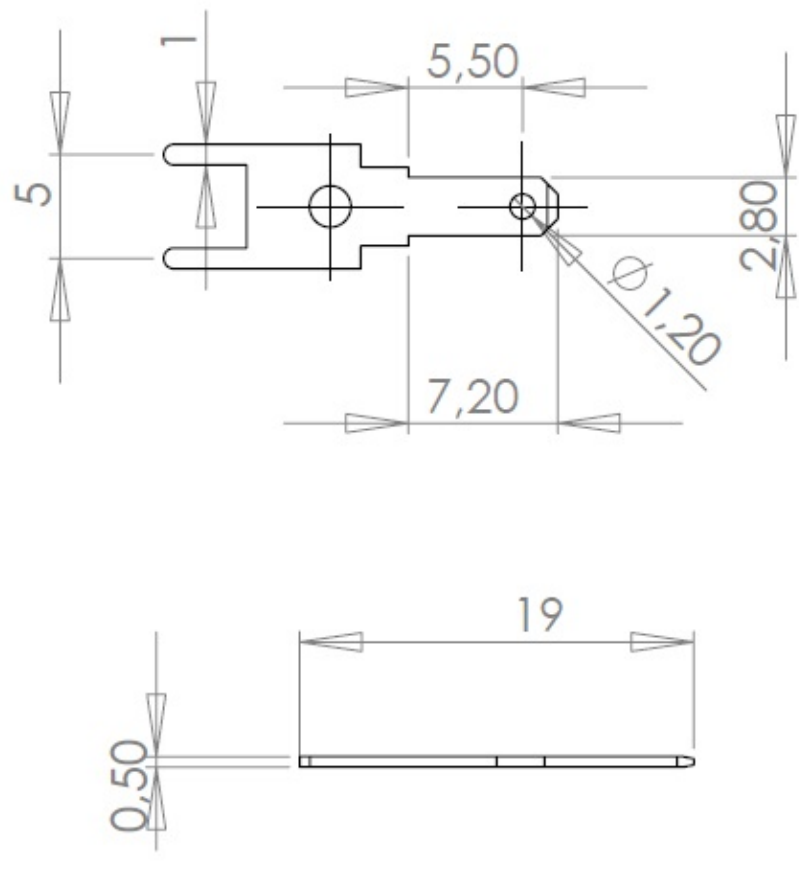

## Matières

L = Laiton étamé RoHS • A = Acier étamé RoHS