

# Pince 956/02 (Diam. 5X20)

## Pinces fusible et portes fusibles - Pinces fusibles

 Acheter ce produit en ligne

[www.mfom.fr](http://www.mfom.fr)

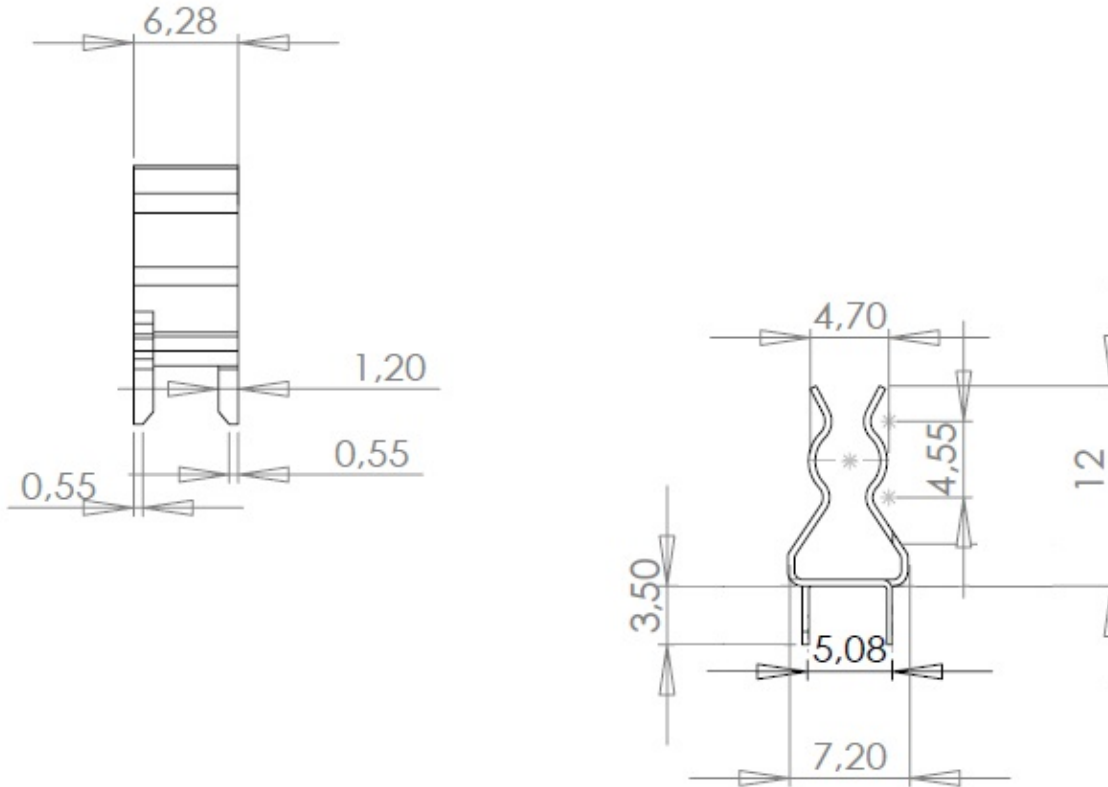

### Matières

956/02 A: Acier • 956/02 L: Laiton

### Autres caractéristiques

Sans ergot d'arrêt